



# **Boligventilasjonsaggregat med varmegjenvinner**

## **VENUS HRV-30**

*... Enkel måte å ventilere din bolig*

 **Thermo**



# VENUS

... Enkel måte å  
ventilere din bolig

**... Ventilasjonsaggregatet med effektiv  
varmgjenvinner for boliger ...**



- ✓ **Kompakte mål**
  - Lengde: 1 000 mm
  - Bredde: 550 mm
  - Høyde: 294 mm
- ✓ **Lav vekt – 18 kg**
- ✓ **Lavt lydnivå – 42 dB (A)**  
\*lydtrykket er mål på 3 meters avstand





# Lufttekniske data

... Enkel måte å ventilere din bolig

- **Maksimum luftmengde – 300 m<sup>3</sup>/h**
  - 3 viftehastigheter

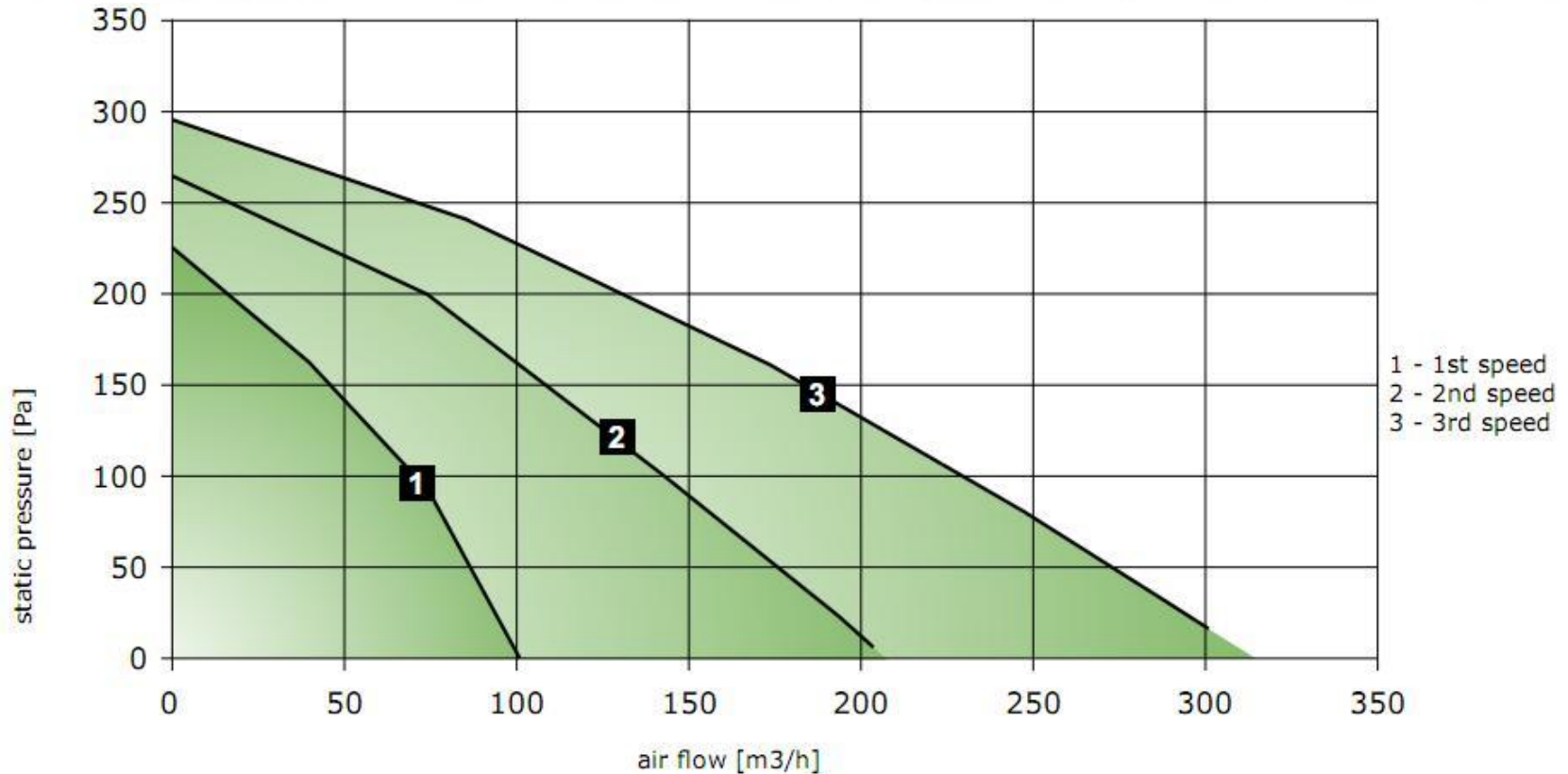



# TEKNISKE DATA

... Enkel måte å ventilere din bolig

- Høy virkningsgrad på varmegjenvinner, opp til 90%
  - Aluminium motstrøms gjenvinner
  - Unik teknologi - "SWIRL CHAMBER SYSTEM"

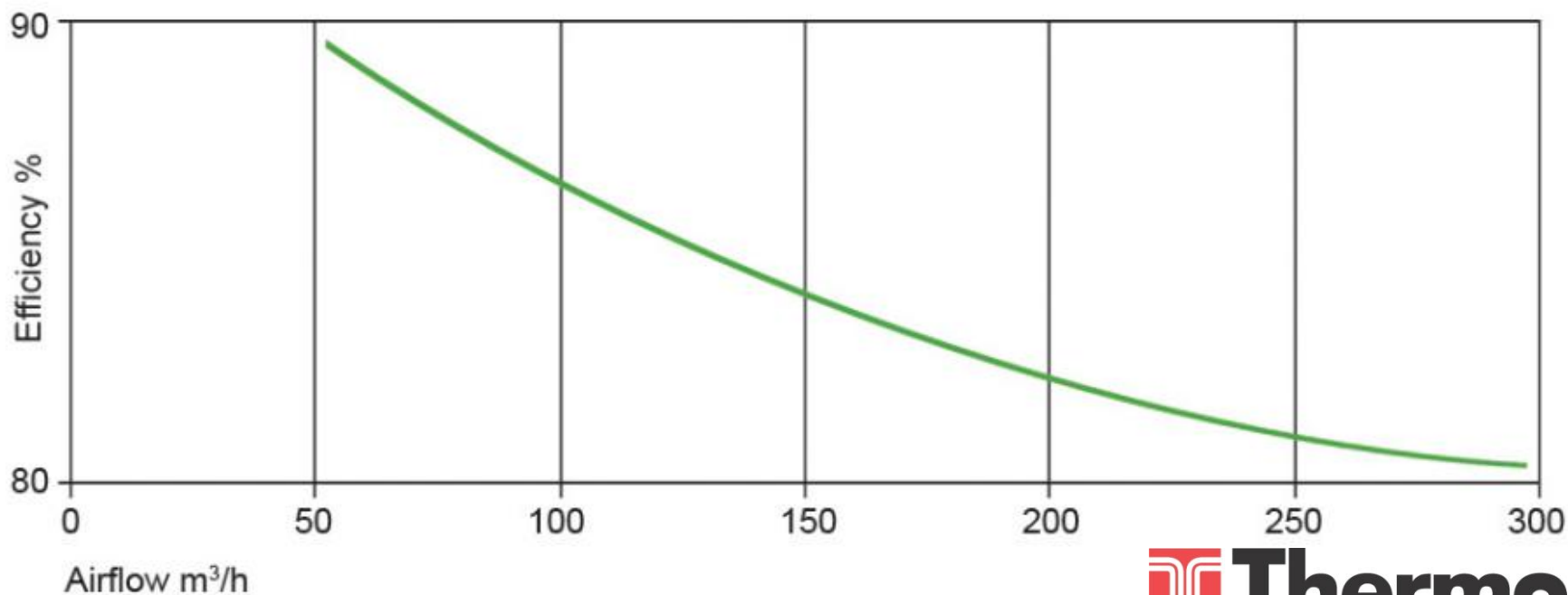

- ✓ I tak, på gulv eller på vegg!

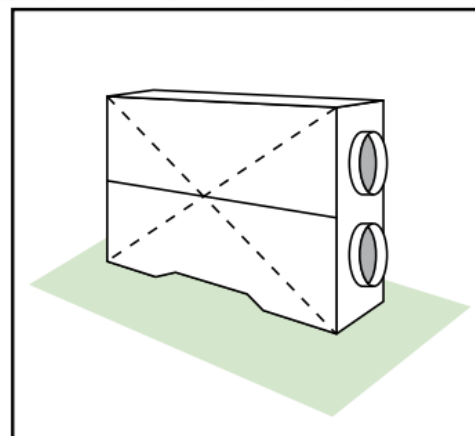
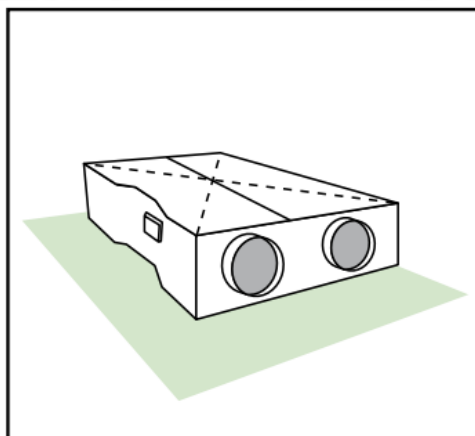
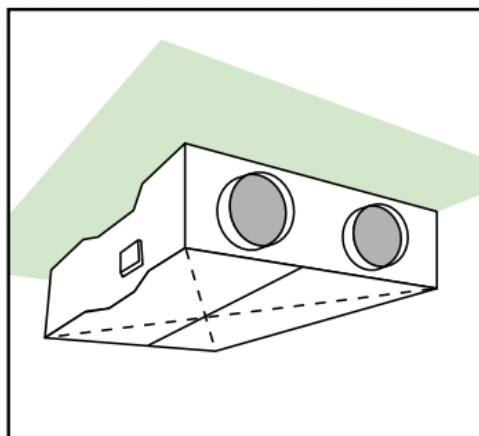

- ✓ Integert frostsikrings beskyttelse
- ✓ Bygget av formstøpt ARPRO (Ethylene Propylene Copolymer)  
tåler temperatur opptil 300°C
- ✓ Plan filtre klasse G4
- ✓ Luftinntak diameter 150 mm



# Hva kan VENUS tilby?

..... Enkel måte å ventilere din bolig

- ✓ Gunstig pris



- ✓ Effektiv ventilasjon med høy virkningsgrad



- ✓ Enkel montering og betjening



- ✓ Lavt lydnivå



✓ Hastighetsregulator



✓ Luftfordelingskammer



✓ Sett for  
luftinntak

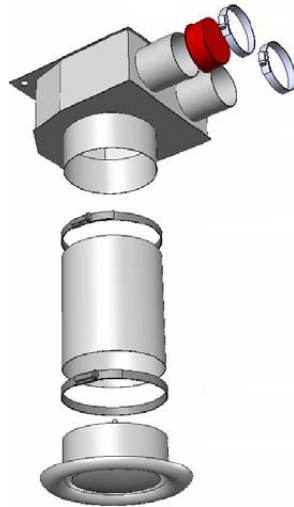

✓ Sett for  
luftilførsel

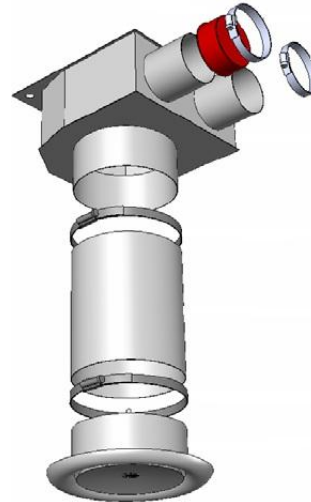



# Anvendelse

..... Enkel måde å  
ventilere din bolig

- ✓ Eneboliger
- ✓ Lav energi hus
- ✓ Passiv hus
- ✓ Boligblokker
- ✓ Leiligheter





# **Boligventilasjon Gjenvinningsaggregat VENUS – HRV-30**

